



Soft Serve Ice Cream Maker

Instruction manual



**Model • Model • Modèle • Modell • Modello • Modelo:
UA034**

Safety Instructions

The appliance must only be used by trained personnel in accordance with these instructions.

Never attempt to use the appliance when any component is faulty or worn.

DANGER OF HIGH VOLTAGE!

Electrical requirements:

Always switch off and disconnect the power supply to the appliance before installation, when not in use, before cleaning and maintenance/service.

Connect the appliance into a suitable power supply with correct voltage and sufficient power capacity. Refer to the rating label on the appliance for voltage and wattage requirements.

This appliance must be earthed.



Connect the appliance to a circuit protected by an appropriate RCD (Residual Current Device).

Failure to comply with these safety instructions will release Polar from any responsibility and the warranty will become null and void.

- Position on a flat, stable surface.
- Install the appliance where it can be overseen by trained personnel.
- **Warning:** When positioning the appliance, ensure the supply cord is not trapped or damaged.

- For indoor use only!
- Always carry, store and handle the appliance in a vertical position.
- DO NOT store products on top of the appliance.
- A service agent/qualified technician should carry out installation and any repairs if required. Do not remove any components or service panels on this product.
- Consult Local and National Standards to comply with the following:
 - Health and Safety at Work Legislation
 - BS EN Codes of Practice
 - Fire Precautions
 - IEE Wiring Regulations
 - Building Regulations
- DO NOT immerse in water, or use jet/pressure washers to clean the appliance.
- Not suitable for outdoor use.
- Always switch off and disconnect the power supply to the appliance before cleaning.
- This appliance is not intended for use by persons (including children) with reduced physical, sensory or mental capabilities, or lack of experience and knowledge, unless they have been given supervision or instruction concerning the use of the appliance by a person responsible for their safety.
- Children should be supervised to ensure that they do not play with the appliance.
- Keep all packaging away from children. Dispose of the packaging in accordance to the regulations of local authorities.
- If the power cord is damaged, it must be replaced by a POLAR agent or qualified technician.

- DO NOT attempt to modify the appliance in any way.
- NEVER leave the appliance unattended when in use.
- Never use accessories which are not recommended by the manufacturer. They could pose a safety risk to the user and might damage the appliance. Only use original parts and accessories, or your warranty will be invalidated.
- POLAR recommend that this appliance should be periodically tested (at least annually) by a Competent Person. Testing should include, but not be limited to: Visual Inspection, Polarity Test, Earth Continuity, Insulation Continuity and Functional Testing.
- POLAR recommend that this product is connected to a circuit protected by an appropriate RCD (Residual Current Device).

Warning: Risk of Fire / flammable materials



Warning: Keep all ventilation openings clear of obstruction. Unit should not be boxed in without adequate ventilation.

- **Warning:** Do not use mechanical devices or other means to accelerate the defrosting process, other than those recommended by the manufacturer.
- **Warning:** Do not damage the refrigerant circuit.

Product Description

UA034 - Soft serve ice cream maker

Introduction

Please take a few moments to carefully read through this manual. Correct maintenance and operation of this machine will provide the best possible performance from your POLAR product.

This appliance is intended for making ice cream from ice cream mix powder or liquified ice cream mix.

Polar will not accept liability for product damage or personal injury in the event that:

- The instructions in this manual have not been followed correctly.
- Unqualified or unauthorized personnel have adjusted the appliance.
- Non-original spare parts are used.
- The appliance has not been handled, cleaned or maintained correctly.
- The appliance is used by personnel not trained or unfamiliar with the usage of the unit.

Pack Contents

The following is included:

- Polar ice cream maker
- Instruction Manual
- Hopper lids (x2)
- Drip tray
- Handles (x3)
- Expanded tube assembly (x2)
- Spare parts:
 1. Spout seals (x2)
 2. Molding caps (x11)
 3. Lubricant (for lubrication of the appliance)
 4. Plastic scrapers (x4, optional and only for metal beaters)
 5. Wave-shaped seals for plastic beaters (x2)
 6. I-shaped seals for middle valve pole (x2)
 7. Ring seals for valve poles (x6)
 8. Stoppers for discharge unit (x2)

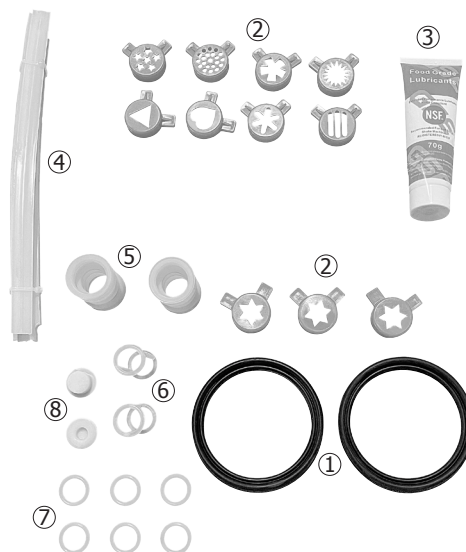

POLAR prides itself on quality and service, ensuring that at the time of unpacking the contents are supplied fully functional and free of damage.

Should you find any damage as a result of transit, please contact your POLAR dealer immediately.

Knowing the appliance

Remove the appliance from the packaging. Make sure that all protective plastic film and coatings are thoroughly removed from all surfaces.

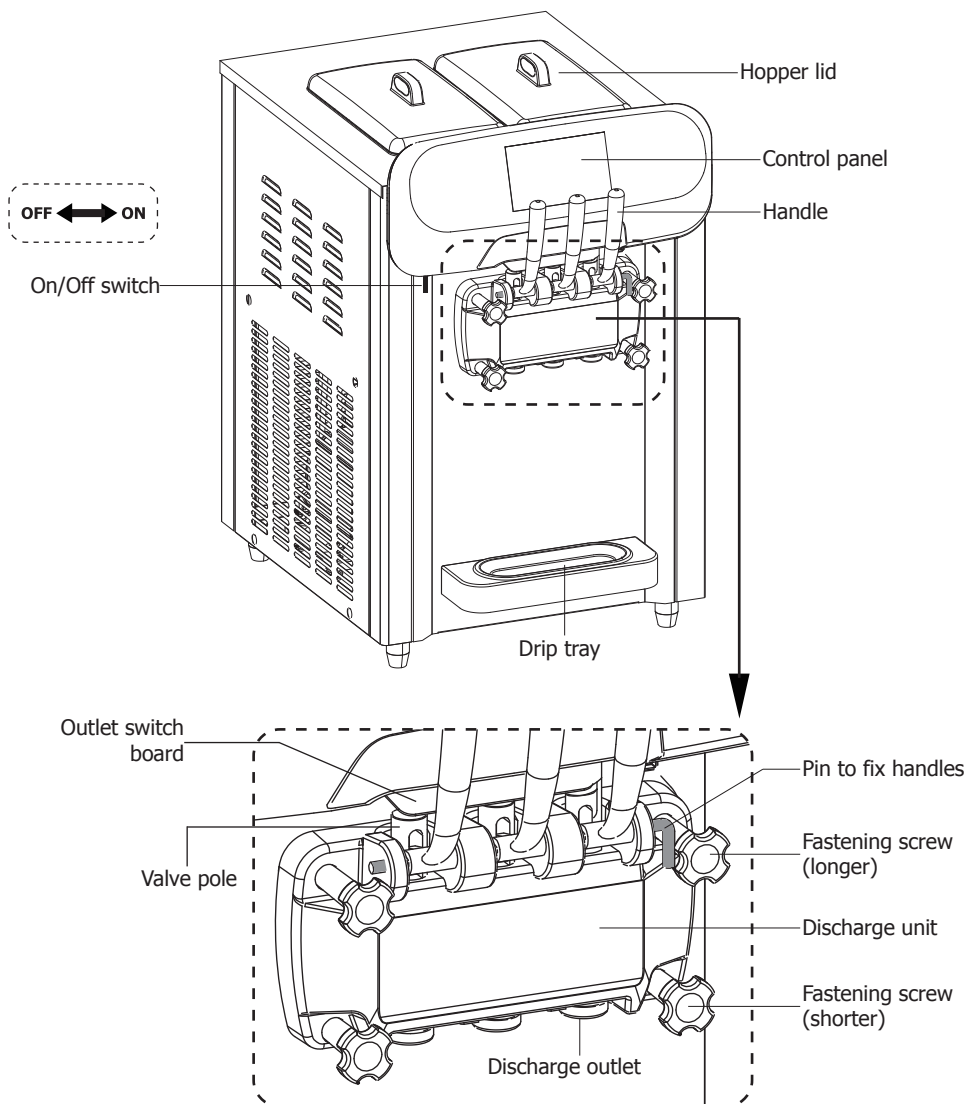

Installation

Before installation, ensure that:

- The appliance is installed indoors.
- The room is adequately lit, well-ventilated and hygienic.
- The location of the appliance is flat and solid, and can support its weight.
- Avoid positioning in direct sunlight or damp areas.
- Adequate clearance is kept around the appliance to enable personnel to operate without constraints.
- Keep away from salty environments to reduce risk of corrosion.
- The appliance may only operate in places with an ambient temperature ranging between 5°C and 38°C.

Not for use in vans or trailers, food trucks or similar vehicles.

If the unit has not been stored or moved in an upright position, let it stand upright for approximately 12 hours before operation. If in doubt allow to stand.

1. To optimize performance and longevity, allow a minimum of 20cm clearance on the top, 2.5cm at the back and left, and 1m at the right.
NEVER LOCATE NEXT TO A HEAT SOURCE.
2. Keep the unit away from splashing water.

Before first time use

Disassembly for deep cleaning

Warning: Switch off and disconnect from the power supply before disassembly, cleaning and maintenance.

Thoroughly clean and maintain the appliance regularly to ensure the appliance is free from bacteria.

Before cleaning or maintenance, ensure to wear proper personal protections (gloves, glasses, etc.).

1. Unscrew the fastening screws then remove the discharge unit.

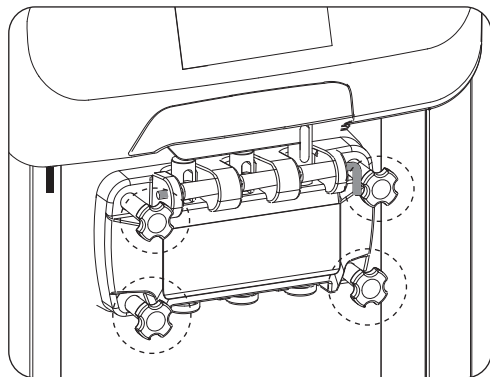

2. Dismante the discharge unit thoroughly.

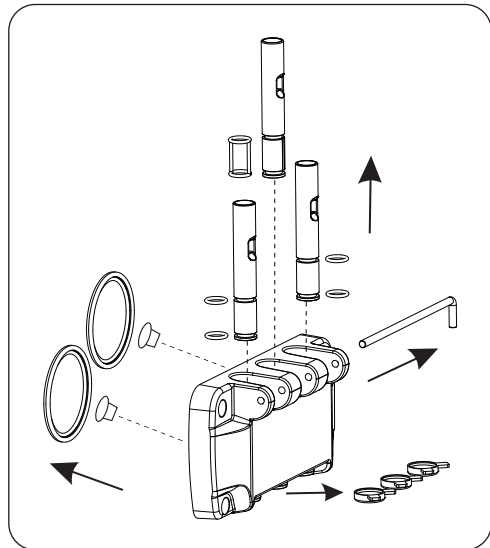

3. Remove the beater assembly.

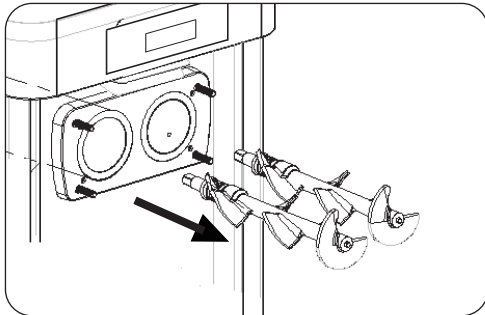

4. Clean and sanitize all the removed parts (including the separately provided handles, expanded tubes, hopper lids, etc), following below instructions:

- Clean the parts with a food-grade detergent.
- Rinse the parts thoroughly with clean water.
- Soak the parts into a sanitizer solution for about 20 minutes (never exceeding 30 minutes).
- Wash the parts again with clean water.
- Let all parts dry completely.

Re-assembly

Warning:

- **Switch off and disconnect from the power supply before re-assembly.**
- **All the removed parts must be re-located in place. Some components must be adequately lubricated to ensure they fit well and work efficiently, or deformation or leakage may occur.**
- **To ensure food hygiene, always clean and sanitize hands thoroughly before operation.**

1. Mount the seals on the beaters.

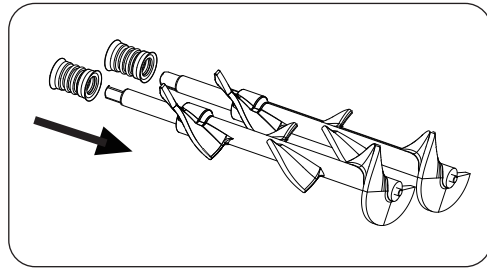

2. Insert the beaters into the appliance and rotate slowly to secure in place.

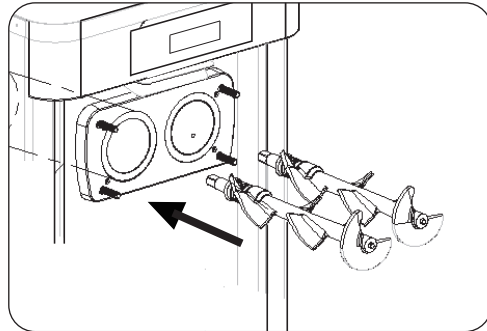

3. Mount the seals on the valve poles.

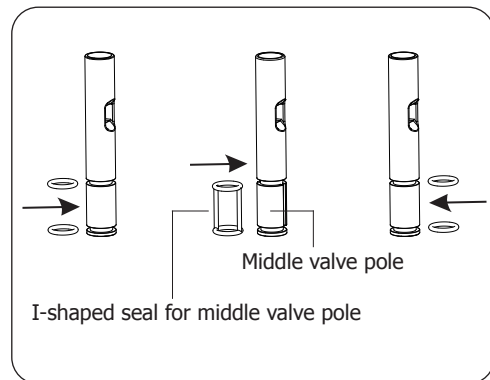

4. Check to ensure each handle is mounted with 2 seals in place.

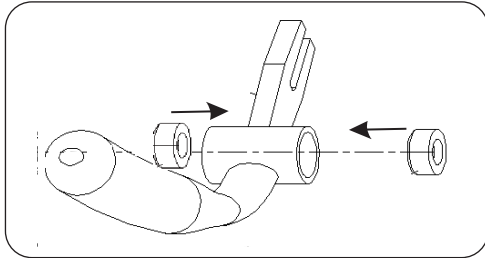

5. Mount the spout seals ① and stoppers ②, molding caps ③, valve poles ④ and handles ⑤ on the discharge unit.

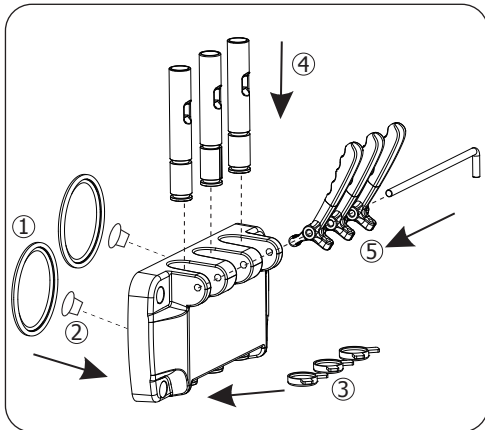

6. Mount the discharge unit onto the 4 studs.

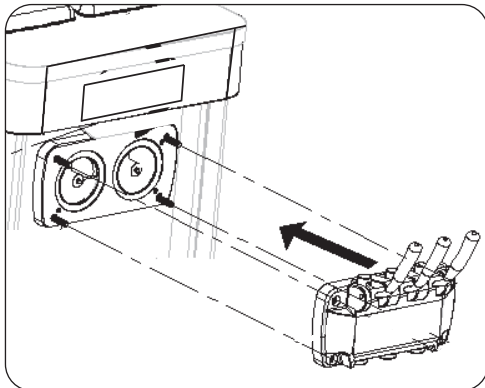

7. Mount the 4 fastening screws, 2 longer ones on the upper position and 2 shorter ones on the lower position.

- **Caution: Always ensure to fix the screws in place, Or leakage may occur.**

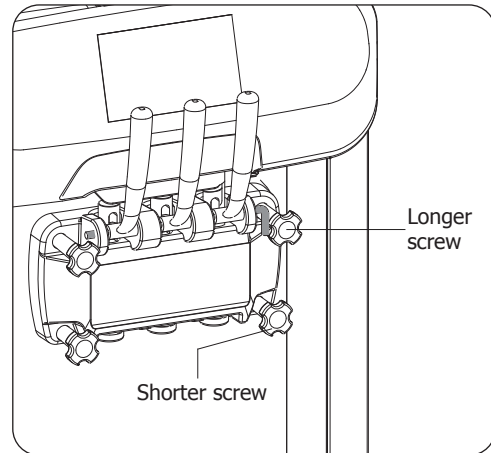

8. Lift up all handles to avoid accidental discharge after unit switched on, then locate the drip tray. The appliance is now assembled for use.

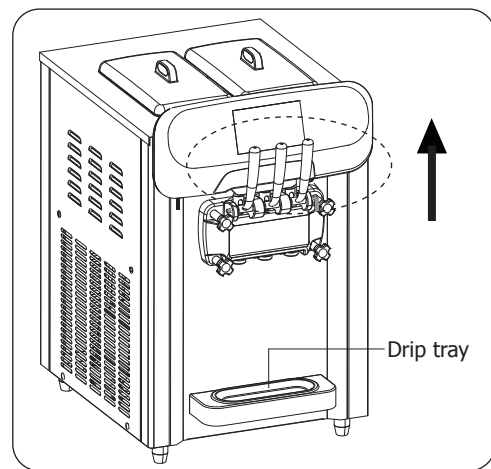

Operation

Before the first time use, always ensure to:

- Let a specialized technician check the appliance functions properly;
- Clean the machine using the easy cleaning function.

Easy cleaning

1. Pour a solution of detergent and warm water into the hoppers but do not exceed the Max level marking. Locate the hopper lids.
2. Connect the appliance to a mains power supply and set the On/Off switch (OFF ↔ ON) to 'ON' position.
3. The control panel lights up then shows the main screen. The appliance is now in Standby.
4. Press 'WASH' to enter the washing screen. The agitating and cleaning system starts to work.

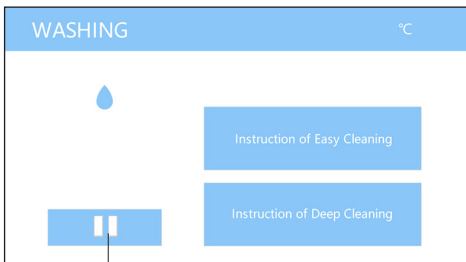
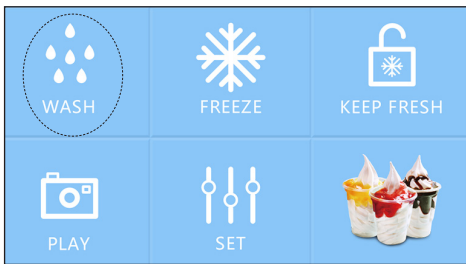

Stop key

5. After cleaning for about 3-5 minutes, pull down the handle to discharge the solution completely into a container. Repeat with clean water for 3-4 times to flush the internal system.
6. After easy cleaning, press the stop key to back to the main screen and enter Standby.

Preparing the ice cream mix

1. Use ice cream mix intended for use in ice cream machines only, either it is powder or concentrate.
2. Mix the powder or Dilute the concentrate with drinking water in a container, always following the manufacturer's instructions. **Or cause damage to the beaters and gear motors may happen. Damage caused by using incorrect mixture will invalidate the warranty.**
For example, when ice cream powder is used, the recommended ratio is 1kg ice cream powder to 2.5-3 litres drinking water.

3. Let the mix settle down for about 5 minutes.

Filling the ice cream mix

Note: Before filling, ensure there is no moisture residual inside the cyclinder.

1. Pull down the handle to raise the valve poles, then fill in small amount of ice cream mix.
2. Water will flow out via the discharge outlets. When seeing the mix is out, raise the handle.
3. Fill the prepared mix into both hoppers, at least covering the hopper bottom.

Warning:

- Do not fill the hoppers with hot liquid.
- This appliance has 2 cylinders to be cooled simultaneously thus always ensure both hoppers are filled with ingredients. Otherwise, the cylinder will freeze and may cause the beater to wear.

Inserting the expanded tube assembly

1. Use food safe lubricant to fit all the seals into place. Place the inner tube into the outer tube

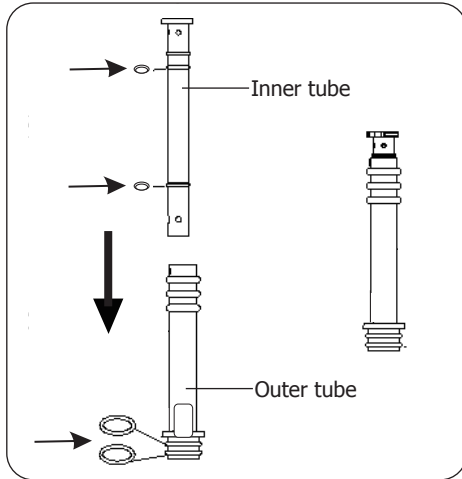

2. **Selecting the feeding hole:** To ensure a stable feeding, the volume into the cylinder can be set by selecting a desired feeding hole. There are 3 holes:

- Big hole: Big volume
- Medium hole: Medium volume (default setting)
- Small hole: Small volume

Pull up the inner tube and rotate horizontally to select. The selected hole size can also be identified by the arrowed hole size mark on the top.

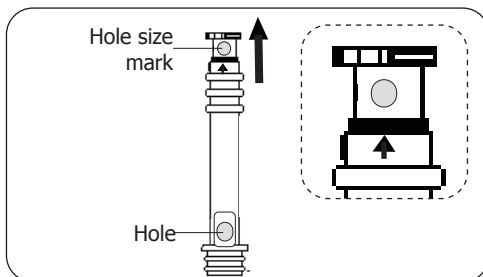

3. Insert the expanded tube into the hopper hole.

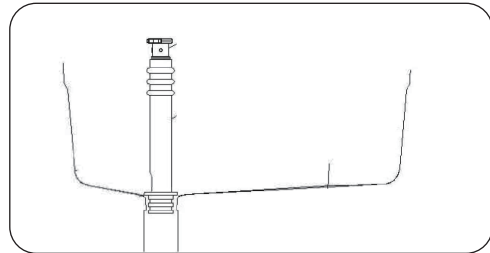

- **Warning:** After switched on, DO NOT put fingers into the feedstock inlet to avoid possible injury.
- **Note:** When not in use for more than 1.5 hours 1.5 hours, ensure to rotate the inner tube to close the expanded tube (as shown below).

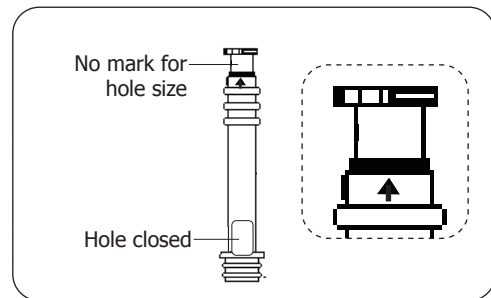

Note:

- **When the ice cream mix is very thick and condensed, it will flow very slowly thus we do not recommend the use of the expanded tube assembly.**

4. Always ensure the Hopper Lids are in place to keep contents hygienic.

Starting to make ice cream

1. While in Standby, press "WASH" again to drop and mix the ingredients for 2-3 minutes.
2. Add more prepared mix into both hoppers, at least 2/3 of the full capacity but below the Max level mark.
3. Press "FREEZE" to start ice cream making. The shape rate will start from 65% and keeps increasing. Discharge about 1/3 of the total mix and put back into the hopper.

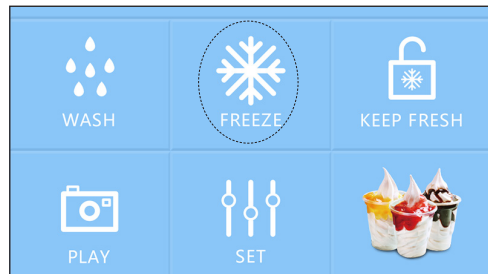

4. After about 15 minutes, shape rate ends at 100% and the appliance ends freezing automatically. Ice cream is now ready for serving.

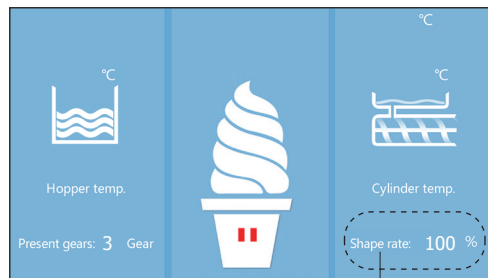

Shape rate

Note: For the first time discharge, the default setting of ice cream hardness is 90%. For consecutive servings, just discharge according to your preferred hardness.

5. For hygiene reason, discard the first 3-4 servings of ice cream created.

Warning: Never attempt to put back the discharge ice cream into the hopper as it may have been contaminated and endanger the customer's health.

6. If desired to switch to other functions, press the stop key to back to the Standby mode.

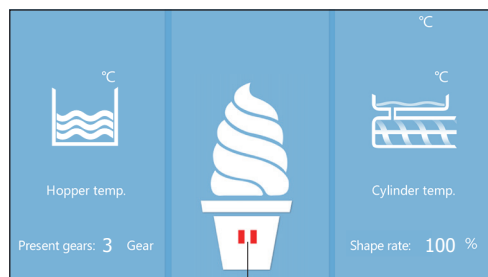

Stop key

Precautions on using the discharge outlets

- Once the ice cream is ready, use the handles to dispense.
- When both hoppers contain different flavours of mix, you can use the middle handle to discharge mixed flavours of ice cream.

If the appliance is not used continuously throughout the day, make sure to:

- Wipe away any ice cream residue that is sticking to the discharge outlet area.
- Spray sanitizer solution around the discharge outlet area (alternatively, wipe with a clean cloth and sanitizer).

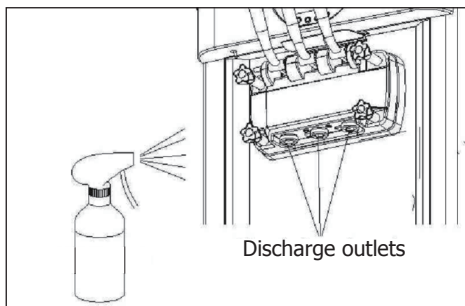

Keeping fresh mode

1. While in Standby, press "KEEP FRESH" to enter keeping fresh mode. This mode will last unless the "Stop" key is pressed.

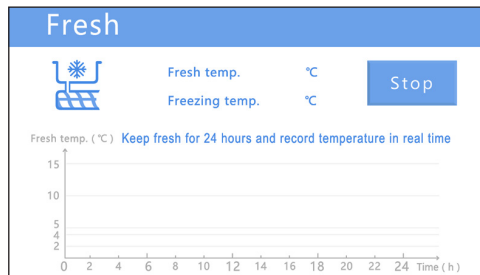
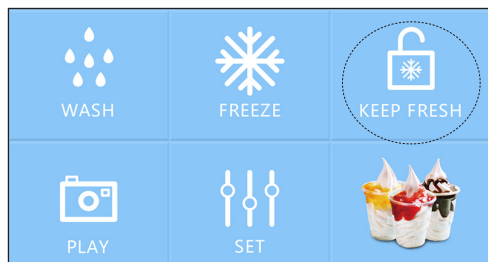

2. If to exit this mode and use other functions, press the "Stop" key.

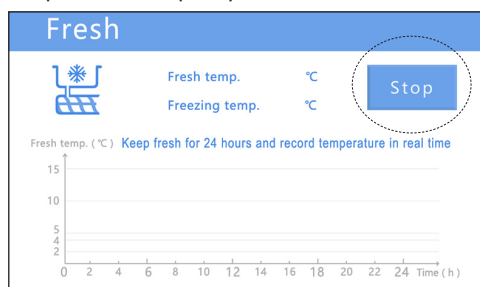

3. The confirmation screen will pop up. Press "YES" to confirm and back to Standby mode.



- Regularly check the temperature of the mix in the hoppers, using a standard thermometer, to make sure it is always kept below the storage temperature.
- Do not store ice cream in the appliance overnight.

To change to use new flavours of ice cream mix

- When to switch to new flavours of ice cream mix, ensure to empty and clean the hoppers first.
 - Transfer the remaining mix in the hoppers into a suitable container and store in a fridge, selecting correct storage temperature and following the applicable hygiene regulations.
 - Discharge any ice cream residues via the discharge outlets and discard.
 - Carry out the "easy cleaning" to clean the hoppers and flush the internal system.
- Fill with new flavours of mix and make ice cream as stated in previous sections.

Presentation mode

- While in Standby, press "PLAY" key to enter presentation mode.

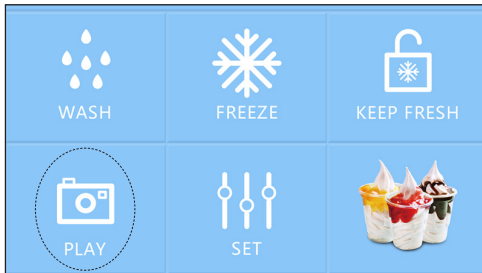

- Press a desired key to check relative instructions. Press "Back" to exit and back to Standby mode.

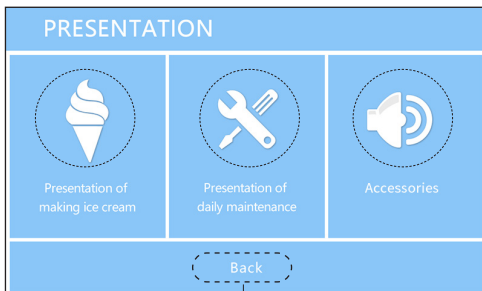

Back key

Setting mode

- While in Standby, press "SET" key to enter setting mode.

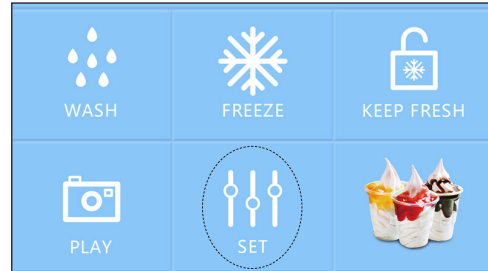

- The password input screen will pop up. Input the default password "121015" and press "OK" to confirm.

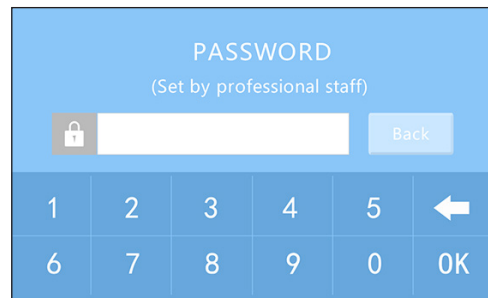

- The setting screen (Page 1) will pop up.

Page 1:

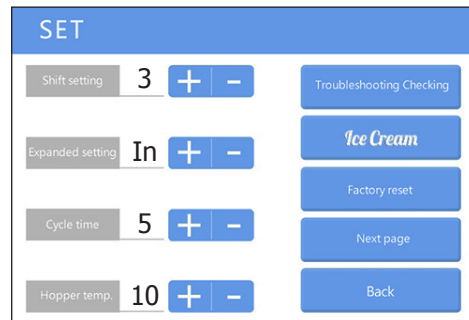

4. Press "Next page" to access Page 2 and "Last page" to back to Page 1.

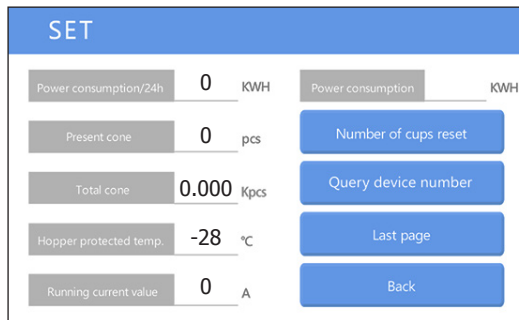
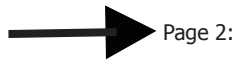

5. Press "+" or "-" to adjust the settings:

Parameter	Range	Default	Remark
Shift setting 	1-12	3	Softest to hardest, the higher the setting is, the harder the ice cream will be
Expanded setting 	High, In, Low, OFF	In (=intermediate)	This setting relates to puffing rate, that is, the air content of ice cream created. Puffing rate is very important for the quality and shape of ice cream. The higher the setting is, the more air will be mixed in to create a more creamy state
Cycle time 	1-15min	5min	When the shape rate reaches 100%, the appliance ends freezing automatically and enters Standby. The standby duration can be set between 1-15min. After the duration collapses, freezing starts automatically
Hopper temp 	1-15°C	10°C	Ice cream mix will be kept to the set temperature
Troubleshooting Checking	If desired, you can press to check the alert screen.		
Factory reset	<ul style="list-style-type: none"> Press to check factory reset screen. Press "Yes" to reset and back to the previous page. <p>Caution: Be careful of the operations as it will restore all the factory default settings.</p> <ul style="list-style-type: none"> If no need for reset, press "Back" to back to the previous page. 		

6. After all setting done, press "Back" to back to Standby mode.

To empty the hoppers at the end of business

Caution:

- **The hoppers must be cleaned and sanitized at least once a day and more frequently depending on the ice cream mix type used, and in any case, in compliance with the applicable hygiene regulations.**
- **NEVER attempt to clean/sanitize the lid while it is installed on the appliance.**

1. Before the hoppers are cleaned, they must be emptied.
2. Remove the hopper lids and expanded tubes.
3. Remove all residual mix from the hoppers with an implement and discard.
4. Discharge any ice cream residues via the discharge outlets and discard.
5. Carry out the "easy cleaning" to clean the hoppers and flush the internal system.

To turn off the appliance

- **After use:** set the On/Off switch  to 'OFF' position to turn off the appliance.
- In case of freezing, switch off and unplug the appliance. Then call POLAR agent or qualified technician.

Cleaning, Care & Maintenance

Warning: Switch off and disconnect from the power supply before cleaning and maintenance.

- Before cleaning or maintenance, ensure to wear proper personal protections (gloves, glasses, etc.).
- Do not use abrasive cleaning agents as they may leave harmful residues.
- DO NOT rinse the base unit. Instead just wipe the outer surface with a damp cloth.
- Empty and clean the drip tray regularly.
- DO NOT wash any parts in a dishwasher.
- DO NOT dry any parts in a conventional or microwave oven.
- Ensure to carry out any cleaning and sanitization with utmost care and on a regular basis to guarantee the quality of the ice cream discharged and compliance with mandatory hygiene standards.
- When all cleaning and maintenance completed, make sure that all parts and seals are set back in place and secured properly.

Disassembly for deep cleaning

Warning:

- **Switch off and disconnect from the power supply before disassembly for deep cleaning and maintenance.**
- **Deep cleaning should be conducted weekly.**

1. Dismantle the appliance as instructed in the previous section "Disassembly for deep cleaning".
2. Clean and sanitize all the removed parts (including the expanded tubes and hopper lids), following below instructions:
 - Clean the parts with a food-grade detergent.
 - Rinse the parts thoroughly with clean water.
 - Soak the parts into a sanitizer solution for about 20 minutes (never exceeding 30 minutes).
 - Wash the parts again with clean water.
 - Let all parts dry completely.

Re-assembly

Warning:

- **Switch off and disconnect from the power supply before re-assembly.**
- **All the removed parts must be re-located in place. Some components must be adequately lubricated (using the Lubricant provided) to ensure they fit well and work efficiently, or deformation or leakage may occur.**

1. Before re-assembly, ensure to check all removed parts are present and free of damage.
2. For perishable consumables such as seals, always ensure to check their integrity and and replace with new ones on a regular basis:

Parts	Replacement period
Ring seals for valve poles and expanded tubes	Every 3 months; Note: Should any wear or deformation is found within the replacement period, replace immediately
I-shaped seals for middle valve pole	
Wave-shaped seals for plastic beaters	
Spout seals	
plastic stoppers	
Plastic scrapers (optional, only for metal beaters)	
Note: Generally the plastic beaters can last 3 years, but if it wears too much beforehand, just replace in time	

3. Re-locate all the removed parts correctly, following the instructions as stated in the previous section "re-assembly".

Easy cleaning

Caution: After re-assembly and before re-starting the appliance for serving, make sure to carry out the easy cleaning cycle.

1. Fill the hoppers with clean water and detergent.
2. Run the easy cleaning mode. For details, please see Section "Easy cleaning".
3. Turn off the appliance.

Periodic maintenance

Caution:

- **Always disconnect power supply before carrying out periodic Maintenance.**
- **The appliance must be checked annually by a specialized technician.**
- **Worn components must be replaced with original spare parts. Never use parts or accessories which are not recommended by the manufacturer. They could pose a safety risk to the user and might damage the appliance.**

Cleaning the condenser	<ul style="list-style-type: none"> • The condenser is part of the refrigeration system and should be cleaned every 6 months, or more often depending on the use frequency/intensity. • Failure to clean the condenser will increase energy consumption, reduce the performance and life of your Polar unit, and thus may invalidate your warranty.
lubricating the gear unit	<ul style="list-style-type: none"> • When used for about 2 years, it is necessary to apply some lubrication oil to the gear unit. Otherwise, it is easy to wear and may affect the performance. • POLAR recommend that a POLAR agent or qualified technician should carry out the adjustment.
Adjusting the drive belt	<ul style="list-style-type: none"> • When used for an extended period of time, the driving belt of the agitating system may become elongated thus needs to be adjusted. • POLAR recommend that a POLAR agent or qualified technician should carry out the adjustment.

Troubleshooting

A qualified technician must carry out repairs if required.

Fault	Probable Cause	Solution
The appliance is not working	The unit is not switched on	Check the unit is plugged in correctly and switched on
	Plug or lead is damaged	Replace Plug or lead
	Fuse in the plug has blown	Replace the plug fuse
	Mains power supply fault	Check mains power supply
Appliance does not work in WASH mode	Wire connection problem	Check the connection and fix if necessary
	Motor failure	Call POLAR agent or qualified technician
Compressor does not work	Low voltage	Connect the appliance into a suitable power supply with correct voltage and sufficient power capacity. Refer to the rating label on the appliance for voltage and wattage requirements
	Control board or compressor failure	Call POLAR agent or qualified technician

Fault	Probable Cause	Solution
The appliance is not cooling	Coolant leakage	Call POLAR agent or qualified technician
	Fan broken	Call POLAR agent or qualified technician to replace the fan
	Airflow obstructed to the condenser	Increase the gap between appliance and obstacles/heat source
	Freezing-up occurred in the inlet hole	Call POLAR agent or qualified technician to replace the fan
	Freeze mode is not selected	Press "FREEZE" to select FREEZE mode
Loud noise	Seals not applied correctly	Put the seals correctly
	Seals not lubricated well	Lubricate the seals
Appliance does not stop	Gear setting is incorrect	Choose the correct gear level
	Condenser is blocked with dust or fan broke down	Clean the condenser with a brush, or check the fan motor can work correctly
No product is discharged	Power failure	Check the power connection
	Ingredient mixture shortage	Add mixture into the hopper
	Sensor switch is broken or incorrectly connected	Replace with a new sensor, or check connection
	Drive belt slips	Check the belt. In case of belt worn out, replace immediately
	Agitator broken	Check the agitator and replace if necessary
	On/off switch is at OFF position	Set the switch to On and press "FREEZE"
Ice cream too soft	Hardness setting too low	Choose a higher gear setting
	Incorrect mixture ratio	Make a new mix of good ratio following instructions for the product
Ice cream too hard	Hardness setting too high	Choose a lower gear setting
	Incorrect mixture ratio	Make a new mix of good ratio following instructions for the product
Mixture leakage	Spout seals not mounted in place	Mount the seals correctly
	Leakage from the front or back of the freezing cylinder	Check if the seals are in good condition or mounted properly. Replace if necessary
Appliance stops automatically shortly after turned on	Low voltage	Connect the appliance into a suitable power supply with correct voltage and sufficient power capacity
	Sensor failure	Turn off then replace with a new sensor

Alarm/Error code	Probable Cause	Solution
'88'	Poor/abnormal refrigeration	Check ventilation and the condenser
'LL" shown, meanwhile buzzer sounds up and appliance stops automatically	Sensor failure	<ol style="list-style-type: none"> 1. Turn off the appliance and check if the magnet is missing 2. Adjust the sensor position 3. If problem still persists, replace with a new one
'55'	Drive belt slips	Check the belt tensioning. In case of belt worn out, replace immediately
'66'	Ingredient mixture shortage	Add mixture into the hoppers
HH	Compressor pressure abnormal	Call POLAR agent or qualified technician
UH	Input voltage exceeds the allowed Max rating	Electrical installation is not in order so have a qualified electrician check it
UL	Input voltage exceeds the allowed Min rating	Electrical installation is not in order so have a qualified electrician check it
RL	Internal temperature below -35°C, temperature sensor fault, or ingredient mixture shortage	Add mixture into the hoppers. If problem persists, call POLAR agent or qualified technician to check the sensor
RH	Internal temperature above 60°C due to poor ventilation, or temperature sensor fault	Move the appliance to a well-ventilated area. If problem persists, call POLAR agent or qualified technician to check the sensor
Shape rate 100% cannot be reached	Refrigerant shortage	Check for leakage and fix, then recharge
	Poor ventilation	Move the appliance to a well-ventilated area
Appliance does not stop after shape rate reaches 100%	Micro switch or PC board is broken	Call POLAR agent or qualified technician to check the components and replace if necessary

Technical Specifications

Note: due to our continuous improvement process, the product specifications are subject to change without notice.

Model	Voltage	Power (W)	Current (A)	Hoppers	Capacity (litres)	Refrigerant charge
UA034	220-240V~ 50Hz	2350W	12A	2	6	R290/140g, R290/35g

Net product Dimensions H x W x D mm	Net Weight (kg)
867.5 x 542 x 781.5	98.00

Electrical Wiring

POLAR appliances are supplied with a 3 pin BS1363 plug and lead.

The plug is to be connected to a suitable mains socket.

POLAR appliances are wired as follows:

- Live wire (coloured brown) to terminal marked L
- Neutral wire (coloured blue) to terminal marked N
- Earth wire (coloured green/yellow) to terminal marked E

This appliances must be earthed.



If in doubt consult a qualified electrician.

Electrical isolation points must be kept clear of any obstructions. In the event of any emergency disconnection being required they must be readily accessible.

Disposal

EU regulations require refrigeration product to be disposed of by specialist companies who remove or recycle all gasses, metal and plastic components.

Consult your local waste collection authority regarding disposal of your appliance. Local authorities are not obliged to dispose of commercial refrigeration equipment but may be able to offer advice on how to dispose of the equipment locally.

Alternatively call the POLAR helpline for details of national disposal companies within the EU.

Compliance

The WEEE logo on this product or its documentation indicates that the product must not be disposed of as household waste. To help prevent possible harm to human health and/or the environment, the product must be disposed of in an approved and environmentally safe recycling process. For further information on how to dispose of this product correctly, contact the product supplier, or the local authority responsible for waste disposal in your area.



POLAR parts have undergone strict product testing in order to comply with regulatory standards and specifications set by international, independent, and federal authorities.

POLAR products have been approved to carry the following symbol:



All rights reserved. No part of these instructions may be produced or transmitted in any form or by any means, electronic, mechanical, photocopying, recording or otherwise, without the prior written permission of POLAR. Every effort is made to ensure all details are correct at the time of going to press, however, POLAR reserve the right to change specifications without notice.

DECLARATION OF CONFORMITY

- Conformanceverklaring • Déclaration de conformité • Konformitätserklärung • Dichiarazione di conformità •
• Declaración de conformidad

Equipment Type · Uitrustingstype · Type d'équipement · Gerätetyp · Tipo di apparecchiatura · Tipo de equipo	Model · Modèle · Modell · Modello · Modelo
U-Series Soft Serve Ice Cream Maker	UA034 (-E & -A)
Application of Territory Legislation & Council Directives(s) Toepassing van Europese Richtlijn(en) · Application de la/des directive(s) du Conseil · Anwendbare EU-Richtlinie(n) · · Applicazione delle Direttive · Aplicación de la(s) directiva(s) del consejo	<p>Low Voltage Directive (LVD) - 2014/35/EU Electrical Equipment (Safety) Regulations 2016 EN 60335-1:2012 +A11:2014 +A12:2017 +A13:2017 +A1:2019 +A14:2019 +A2:2019 +A15:2021 EN IEC 60335-2-24:2022 +A11:2022 EN62233:2008</p> <p>Electro-Magnetic Compatibility (EMC) Directive 2014/30/EU - recast of 2004/108/EC Electromagnetic Compatibility Regulations 2016 (S.I. 2016/1091) EN IEC 55014-1: 2021 EN IEC 55014-2: 2021 EN IEC 61000-3-2: 2019+A1:2021 EN 61000-3-3: 2013+A2:2021</p> <p>Restriction of Hazardous Substances Directive (RoHS) 2015/863 amending Annex II to Directive 2011/65/EU Restriction of the Use of Certain Hazardous Substances in Electrical and Electronic Equipment Regulations 2012 (S.I. 2012/3032)</p>
Manufacturer Name · Naam fabrikant · Nom du fabricant · Name des Herstellers · Nome del fabbricante · Nombre del fabricante	Polar

I, the undersigned, hereby declare that the equipment specified above conforms to the above Territory Legislation, Directive(s) and Standard(s).

Ik, de ondergetekende, verklaar hierbij dat de hierboven gespecificeerde uitrusting goedgekeurd is volgens de bovenstaande Richtlijn(en) en Standaard(en).

Je soussigné, confirme la conformité de l'équipement cité dans la présente à la / aux Directive(s) et Norme(s) ci-dessus

Ich, der/die Unterzeichnende, erkläre hiermit, dass das oben angegebene Gerät der/den oben angeführten Richtlinie(n) und Norm(en) entspricht.

Il sottoscritto dichiara che l'apparecchiatura di sopra specificata è conforme alle Direttive e agli Standard sopra riportati.

El abajo firmante declara por la presente que el equipo arriba especificado está en conformidad con la(s) directiva(s) y estándar(es) arriba mencionadas.

Date · Data · Date · Datum · Data ·
Fecha

Signature · Handtekening ·
Signature · Unterschrift Firma ·
Firma

Full Name · Volledige naam · Nom et
prénom · Vollständiger Name · Nome
completo · Nombre completo

Position · Functie · Fonction ·
Position · Qualifica · Posición

Manufacturer Address · Adres
fabrikant · Adresse du fabricant ·
Adresse des Herstellers · Indirizzo del
fabbricante · Dirección del fabricante

22 th Apr 2024		
DocuSigned by: <i>Ashley Hooper</i> B39382C9FD9C478...	DocuSigned by: <i>Eoghan Donnellan</i> D352874F7FAB460...	DocuSigned by: <i>Brendan Denmeade</i> 386FAD00DFE8483...
Ashley Hooper	Eoghan Donnellan	Brendan Denmeade
Group Head of Product Quality & Compliance	Commercial Manager/ Importer	Commercial Manager/ Responsible Supplier
Fourth Way, Avonmouth, Bristol, BS11 8TB United Kingdom	Unit 9003, Blarney Business Park, Blarney, Co. Cork Ireland	15 Badgally Road, Campbelltown NSW 2560





UK	+44 (0)845 146 2887
Eire	
NL	040 – 2628080
FR	01 60 34 28 80
BE-NL	0800-29129
BE-FR	0800-29229
DE	0800 – 1860806
IT	N/A
ES	901-100 133

POLAR



<http://www.polar-refrigerator.com/> 

UA034_EN_A5_v1_2024/04/30