



VACUUM SEALER SE-204

Tabletop model. 4 m³/h. 280 mm



FOOD PRESERVATION AND SOUS-VIDE
VACUUM PACKING MACHINES • SENSOR LINE



SALES DESCRIPTION

280 mm sealing bar.
4 m³/h Busch vacuum pump.
Vacuum controlled by sensor.

- ✓ Powered by Busch.
- ✓ Vacuum controlled by sensor.
- ✓ Vacuum PLUS.
- ✓ Digital keyboard.
- ✓ Control panel equipped with display indicating the exact vacuum percentage.
- ✓ "Pause" button to marinate food.
- ✓ Safe liquid packing thanks to sensor control.
- ✓ Double seal.
- ✓ Cordless sealing bar.
- ✓ Bag-sealing programme.
- ✓ Pulse-controlled decompression.
- ✓ Vac-Norm ready with Automatic decompression.
- ✓ Stainless steel body and chamber. Deep-drawn chamber.
- ✓ Damped transparent lid of highly durable polycarbonate.
- ✓ Dry-oil programme for drying the pump.
- ✓ Working hours counter for oil changes.
- ✓ Safety system with protection against vacuum failure.
- ✓ NSF-listed model.

INCLUDES

- ✓ Sensor controls.
- ✓ Up to 10 seconds of extra vacuum pull.
- ✓ Soft air function.
- ✓ Dry oil cycle.
- ✓ Busch pump.
- ✓ NSF approved.
- ✓ Clear methacrylate lid.
- ✓ Filling plate.

OPTIONAL

- Vacuum packing bags.
- External vacuum kit for Vac-Norm, containers and accessories.
- Additional filling plates.

ACCESSORIES

- Filling plates
- Vac-norm containers
- Vac-norm external vacuum kits
- Smooth bags for vacuum packing

SPECIFICATIONS

Pump capacity: 4 m³/h
 Pump capacity (60 Hz): 5 m³/h
 Bar length: 280 mm
 Total loading: 100 W
 Vacuum pressure (maximum): 2 mbar

Internal dimensions

- ✓ Width: 288 mm
- ✓ Depth: 333 mm
- ✓ Height: 110 mm

External dimensions (W x D x H)

- ✓ Width: 337 mm
- ✓ Depth: 431 mm
- ✓ Height: 307 mm

Net weight: 24.2 kg

Background noise: 32 dB(A)

Crated dimensions

[n:embalaje_ancho] x [n:embalaje_fondo] x [n:embalaje_alto] [m:embalaje_ancho]

Gross weight: 27.2 kg

AVAILABLE MODELS

1140620 SE-204 230/50-60/1

1140621 SE-204 120/50-60/1

* Ask for special versions availability





VACUUM SEALER SE-204

Tabletop model. 4 m³/h. 280 mm



FOOD PRESERVATION AND SOUS-VIDE
VACUUM PACKING MACHINES · SENSOR LINE

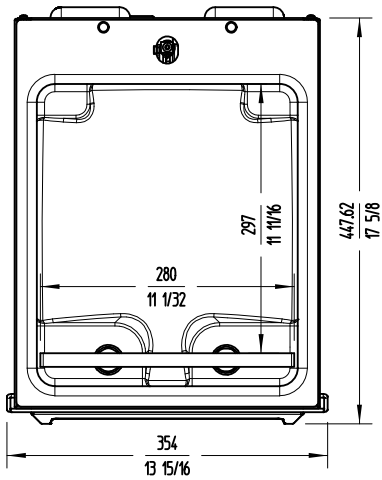
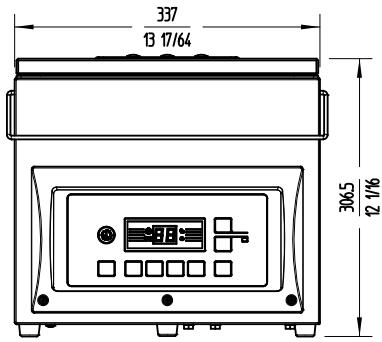

www.sammic.co.uk

Food Service Equipment Manufacturer

Unit 2, Trevanah Road
Troon Industrial Park
LE4 9LS - Leicester

uksales@sammic.com
Tel.: +44 0116 246 1900



Project	Date
Item	Qty
Approved	