



F61/301 - IMC IMChip CS-C1 Counter-top Potato Chipper - W 400 mm - 0.18 kW [exc. knife block/blades]

The compact, powerful CS-C1 chipper is the ideal solution for kitchens that need to produce a high volume of perfectly-cut chips, quickly.

- ✓ Able to produce 25kg of chips per minute.
- ✓ Compact design, with flexible mounting options, to suit kitchens of any size.
- ✓ Screw-down, rigid knife block provides perfect cut every time with little waste.
- ✓ Extra large hopper, with safety interlocks, allows quick and easy loading.
- ✓ Safe, single blade design for quick removal and replacement.
- ✓ Engineered using heavy-gauge stainless steel, for longevity and easy cleaning.
- ✓ UK 3 pin plug allows users to simply plug in and switch on.

Specifications

Summary

Brand	IMC
Range	IMChip
Series	CS Chipper
Power Type	Electric
Unit Type	Counter-top
Available in UK Only	No
UK Warranty	2 Years Parts and Labour Warranty
Export Warranty	Contact your local dealer
Mounting	Drainer; Worktop; Stand [optional]
GTIN	5056105198895

Power and Performance

Total Power kW	0.18
HP	0.24
IP Rating	IP55

Key Specifications

Operator Safety	Interlocks
------------------------	------------

Capacity

Capacity Kg per Hour	1500
Hopper Load kg	12

Weights and Dimensions

Unit Height (External) mm	550
Unit Width (External) mm	400
Unit Depth (External) mm	692
Net Weight Kg	42

Supply Connections

Requires Installation	No
Requires Electrical Supply	Yes
UK 3 Pin Plug	Yes
Requires Hardwiring	No
Single Phase Amps	2.4
Single Phase Voltage	240

Shipping

Packed Weight Kg	48.5
Packed Height cm	84
Packed Width cm	68
Packed Depth cm	42.5

Available Accessories

S61/128	Blades for CS-C1/PC2 Chipper Knife Block - 17 mm x 14 mm [fits S61/115 & S61/144 blocks]
S61/129	Blades for CS-C1/PC2 Chipper Knife Block - 14 mm x 14 mm [fits S61/114 & S61/151 blocks]

Available Accessories

S61/134	Blades for CS-C1/PC2 Chipper Knife Block - 12 mm x 12 mm [fits S61/135 & S61/145 blocks]
S61/140	Stand for CS-C1/PC2 Chipper
S61/141	Bucket Shelf for CS-C1 Chipper
S61/142	Bucket for CS-C1 Chipper [B1/Solid]
S61/143	Bucket for CS-C1 Chipper [B2/Perforated]
S61/144	Knife Block - 17 mm x 14 mm - for CS-C1 Chipper [includes S61/128 Blade]
S61/145	Knife Block - 12 mm x 12 mm - for CS-C1 Chipper [includes S61/134 Blade]
S61/151	Knife Block - 14 mm x 14 mm - for CS-C1 Chipper [includes S61/129 Blade]
S61/166	Static Potato Tank for CS-C1 Chipper [T1/approx. 18 bags]
S61/167	Static Potato Tank for CS-C1 Chipper [T2/approx. 12 bags]
S61/169	Static Potato Tank for CS-C1 Chipper [T3/approx. 14 bags]
S61/170	Static Potato Tank for CS-C1 Chipper [T4/approx. 10 bags]
S61/171	Static Low Potato Tank for CS-C1 Chipper [T5/approx. 10 bags]
S61/183	Blades for CS-C1/PC2 Chipper Knife Block - 21 mm x 17 mm [fits S61/182 & S61/184 blocks]
S61/184	Knife Block - 21 mm x 17 mm - for CS-C1 Chipper [includes S61/183 Blade]
S61/201	Mobile Potato Tank for CS-C1 Chipper [T1/approx. 18 bags]
S61/202	Mobile Potato Tank for CS-C1 Chipper [T3/approx. 14 bags]
S61/203	Mobile Potato Tank for CS-C1 Chipper [T2/approx. 12 bags]
S61/204	Mobile Potato Tank for CS-C1 Chipper [T4/approx. 10 bags]
S61/205	Mobile Low Potato Tank for CS-C1 Chipper [T5/approx. 10 bags]

Technical Picture

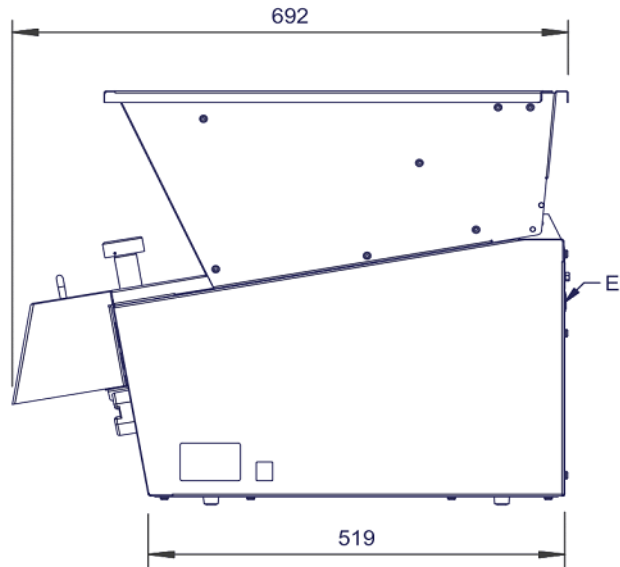
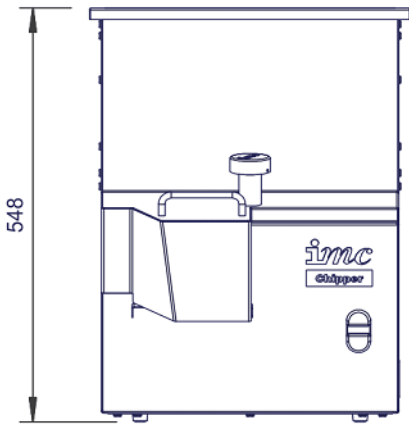
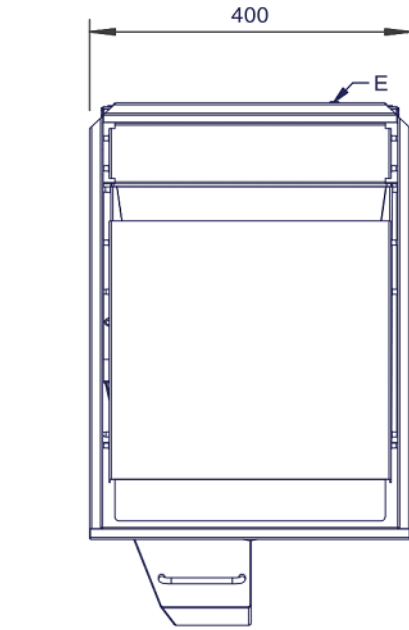

Lincat Limited

Whisby Road,
Lincoln, LN6 3QZ,
United Kingdom

Company No: 2175448

A member company of



Customer Care

Tel: +44 1522 875500
Email: care@lincat.co.uk

Export Customers

Tel: +44 1522 875536
Email: export@lincat.co.uk

Opening Hours

Monday – Friday:
8.30am – 5pm