



Waffle Baker

Instruction Manual



Please read this instruction manual carefully before operating this equipment

Safety Tips



Read this instruction manual before using and keep them available at all times!

This instruction manual contains information about the installation, operation and maintenance of the device and should be consulted as an important source of information and reference guide.

Awareness of the safety instructions and instructions for use in this manual will ensure the safe and correct use of the device.

In addition to the information given here, you should comply with any local Health and safety Controls and generally applicable safety regulations. The instruction manual forms part of the product and should be kept near the device and easily accessible for anyone carrying out the installation, servicing, maintenance or cleaning.

Please keep these instructions and give them to future owners of the device.

Safety

This device is designed in accordance with the presently applicable technological standards. However, the device can pose a danger if handled improperly and inappropriately.

All persons using the device must follow the recommendations and instructions in this instruction manual.

Safety instructions

- The device is not intended for use by individuals (including children) with physical or mental disabilities, insufficient experience, and/or insufficient knowledge unless such persons are under the care of a person responsible for their safety or have received instructions regarding appropriate use of the device.
- Children should be observed to ensure that they are not playing with the device.
- Never leave the device unattended when in use. • Only use the device indoors.
- The device is not adapted for use with an external timer or remote control.
- This device may only be operated in technically proper and safe condition.

- Prevent access of children to the package materials like plastic bags and foamed polystyrene elements. Suffocation hazard!
- Only a qualified technician and using original spare parts and accessories should carry out repairs and maintenance of the device. Do not attempt to repair the device yourself.
- Do not use any accessory or spare parts that have not been recommended by the manufacturer. These can be dangerous for the user or lead to damages of the device or personal injury, and further, the warranty expires.
- To prevent hazards and to ensure optimum efficiency, no modifications or alterations to the device that are not explicitly approved by the manufacturer may be undertaken.



DANGER! Electric shock hazard!

To avoid the hazard results please follow the safety instructions below.

- Never allow the power cable to come into contact with heat sources or sharp edges. The power cable should not hang over the side of the working surface. Ensure that no one can step on or trip over the cable.
- The power cable must not be folded, bent or tangled, and must always remain fully unrolled. Never place the device or other objects on the power cable.
- Do not lay the power cable over carpets or other inflammable materials. Do not cover the cable. Keep away the cable from operating range and do not immerse it into water.
- Check the power cord regularly for damage. Do not use the appliance if the power cord is damaged. If this cable is damaged, it must be replaced by customer service or a qualified electrician in order to avoid dangers.
- The supply cable must be disconnected from the socket only by pulling the plug.
- Never carry or lift the device by the supply cable.
- In any case do not open the device housing. In case of electrical or mechanical modifications the electric shock hazard will occur.
- Do not use any acid agents and make sure no water ingresses the device.
- Never operate the device with moist hands or standing on wet floor.

- Disconnect the device from the electric power supply.
 - when the device is not used,
 - in case of anomalies during operation,
 - before cleaning.



HOT SURFACE! Burn hazard!

Follow the safety instructions listed in order to avoid the hazard:

- The housing and the grill plates of the appliance become very hot. during operation. Do not touch them with bare hands. Use always the operating handle in order to open the device. Use appropriate kitchen utensils for laying and taking of food.
- Also after switching off, the device remains hot for some time. Before cleaning or moving it to another place wait until the device cools down first.
- Never move this appliance during operation.



WARNING! Fire or explosion hazard!

Follow the safety instructions listed in order to avoid the hazard:

- To avoid the fire hazard and the damages of the device never place the kitchen utensils, towels, paper, etc. on the heating plates.
- Never operate the device near combustible, easily flammable materials (e.g. petrol, spirit, alcohol etc.). They evaporate through heating and in case of contact with ignition sources deflagrations can occur which can lead to serious personal injuries and property damages.
- When a fire arises disconnect it from the power supply before you initiate appropriate measures for fire-fighting. Provide sufficient supply of fresh air.

Caution: Never extinguish the fire with water when the power plug is connected to the socket. Electric shock hazard!

Warning:

Improper installation, adjustment, alteration, service or maintenance can cause property damage, injury or death. Read the installation, operation and maintenance instructions thoroughly before installing or servicing this appliance.

For your safety

Do not store gasoline or other flammable liquids in the vicinity of this or any other appliance.

WARNING: FIRE HAZARD

The area where the appliance is installed must be kept clear of combustibles and flammables. This includes mops, rags, grease, wrapping paper and electrical cords.

Warning

Electrical Grounding Instructions

This appliance is equipped with a three-prong (grounding) plug for your protection against shock hazard and should be plugged directly into a properly grounded three-prong receptacle. Do not cut or remove the grounding prong from this plug.

Notice

This appliance is designed for use in non-combustible locations only. Install the appliance on a firm, level, non-combustible surface. For servicing, a clearance of 6 inches (15cm) from rear of the appliance to wall should be kept.

General information

The equipment adopts contacted switch and LED digital panel. The equipment can be set the heating temperature and heating time. It can alarm automatically when it reaches the setting time. The tray can be winded around the shaft 180°clockwise or anticlockwise, easy to operate. The two head have two independent circuit diagrams, and can be used independently.

1. Technical Parameter

Model	WB-03D	WB-03D-2
Voltage	220~240V	220~240V
Frequency	50~60Hz	50~60Hz
Power	1000W	1000W×2
Dimension	255×440×320mm	510×440×320mm
Temperature Range	124℃~230℃	124℃~230℃
Time Range	99'59"~00'00"	99'59"~00'00"

2. Installation and Operation

- 2.1 The using voltage must be coordinated with the supply voltage.
- 2.2 Install a protect device before the socket, and make sure the well ground connection.
- 2.3 Place the equipment on a stable working table. Please let the equipment be far away from the inflammable substance.
- 2.4 Don't touch the tray, lid and handle when it warm-up in case of scald.
- 2.5 Use the wet towel that has cleaner to clean the equipment. Don't clean it with a water jet. Don't dip the equipment into the water, otherwise, it will damage the control panel and other accessories, and cause any accident.
- 2.6 The function of the time setting only alarms the operation time, and the equipment won't cut off the power. So the operator should operate it on time.
- 2.7 Install the unit on an even surface.
- 2.8 The power cord should not touch any hot parts.
- 2.9 When a thunder is coming, unplug the plug and stop using the appliance at once.

3. Operation Instruction

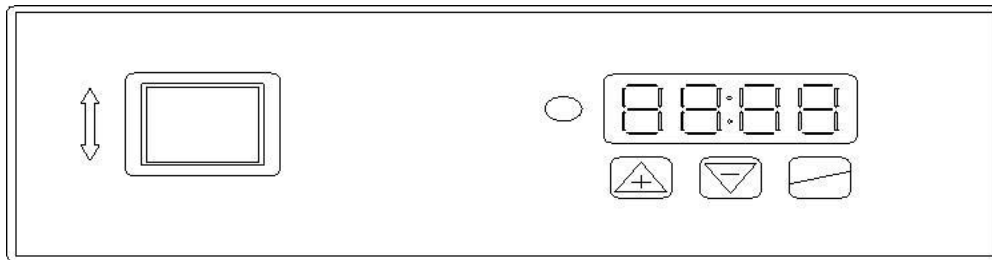

3.1 When the power on, the buzzer will sound “du, du, du” for three times. At the same time, the LED will appear the previous setting time. Then, it will be in this setting time state. If you press the “START/STOP” key, the time will countdown to zero according to the appeared time. When it reaches the setting time, the buzzer will sound “du, du, du”. If you press the “START/STOP” key again, the alarm will stop and appear the presetting time.

3.2 Time setting: If the list is on temperature setting list, press the “SET” key, and it will turn to the time setting list. During setting the time, first, press the “+”(or “-”) key, then press the “START/STOP” key, you can set the time. During setting the time, don’t set free the “+”(or “-”) key. If you press the “START/STOP” key one time, the time will increase (or reduce) one second. If you press the “START/STOP” key continuously, the time will increase (or reduce) very fast. The time range is from 00’00” to 99’59”. Please note: If you press the “START/STOP” key only or press the “START/STOP” key first, the list will count down to zero automatically.

3.3 Temperature setting: If the list is on time setting list, first press the “SET” key, at the same time, press the “START/STOP” key one time, then it will turn to the temperature setting list. If you press the “+”(or “-”) key one time, the temperature will increase(or reduce)one degree. The temperature range is from 124°C to 230°C (255.2oF~446oF) . When the setting temperature is higher than the temperature the probe can measure, it will connect to the electric element automatically. It will stop heating when it reaches the setting degree.

3.4 Time counting: Press the “START/STOP” key when the list is on time setting, and the time will countdown to zero according to the appeared time. When it reaches the setting time, the buzzer will sound “du, du, du”. If you press the “START/STOP” key again, the alarm will stop and appear the presetting time.

3.5 The panel can store the previous setting time and temperature, and the panel can check out the mistake automatically .If the probe was damaged in the using time, the electric element will stop heating, and appears “Err” in the panel.

3.6 According the above instructions, the operator can set the time and temperature according to different favors. For example, if you want bake cake, preset the time to 4min, and the temperature to 170°C (338oF) . Pour the material to the down tray, then close the trays, and press the “START/STOP” key. When it reaches the setting time, the buzzer will alarm, and remain the operator get the food out of the tray. If the operator didn’t take them on time, the cakes will burn. Generally speaking, the more longer time, the higher temperature, the deepen color. If the cooking time is too short, the food will not be cooked well and its color is not good.

4. Circuit Diagram

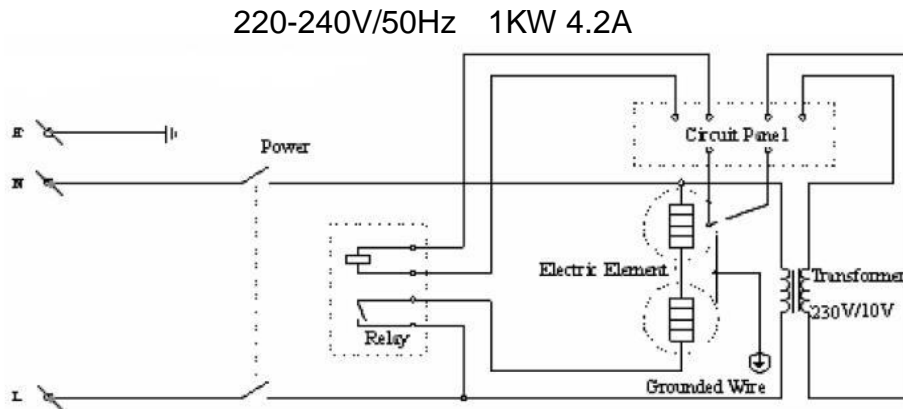

5. The Diagram

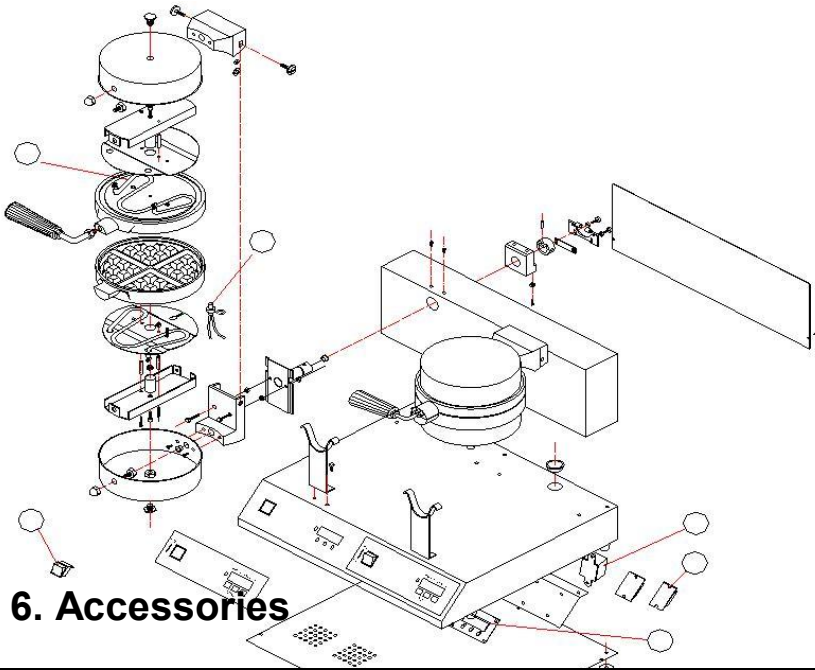

6. Accessories

Number	Name	Specification	Qty
1	Electric Element	Stainless steel $\phi 6.5\text{mm}$ 、115VAC、500W	4
2	Thermocouple	250℃	2
3	Switch	250VAC、16A	2
4	Contacted Panel	LED	2
5	Contactor	12VDC—30A240VAC (69-31142-012)	2
6	Transformer	EI-35、230VAC50Hz—12.0VAC200mA	2

7. Daily checking

Check the appliance before and after use. Before using, make sure the appliance is clean. Be certain that the power cord is not worn out or broken. When in use, make sure no unpleasant smell is present and there is no any unusual noise.

This manual must be read and understood by all persons using or installing this appliance. Contact your local dealer if you have any questions concerning installation, operation or maintenance of this equipment.

8. Waste disposal

Discarding old devices

At the end of its service life the discarded device has to be disposed in accordance with the national regulations. It is advisable to contact a company which is specialized in waste disposal, or just contact the local disposal service in your community.

WARNING!

To exclude any abuse and the dangers involved make the waste device unfit for use before disposal. For that purpose disconnect device from mains supply and remove mains connection cable from the device.

CAUTION!

For the disposal of the device please consider and act according to the national and local rules and regulations.

